

Sheet: /
 File: halow-53mhz-converter-1.kicad_sch

Title:	
Size: A4	Date:
KiCad E.D.A. 9.0.8	Rev:
	Id: 1/7

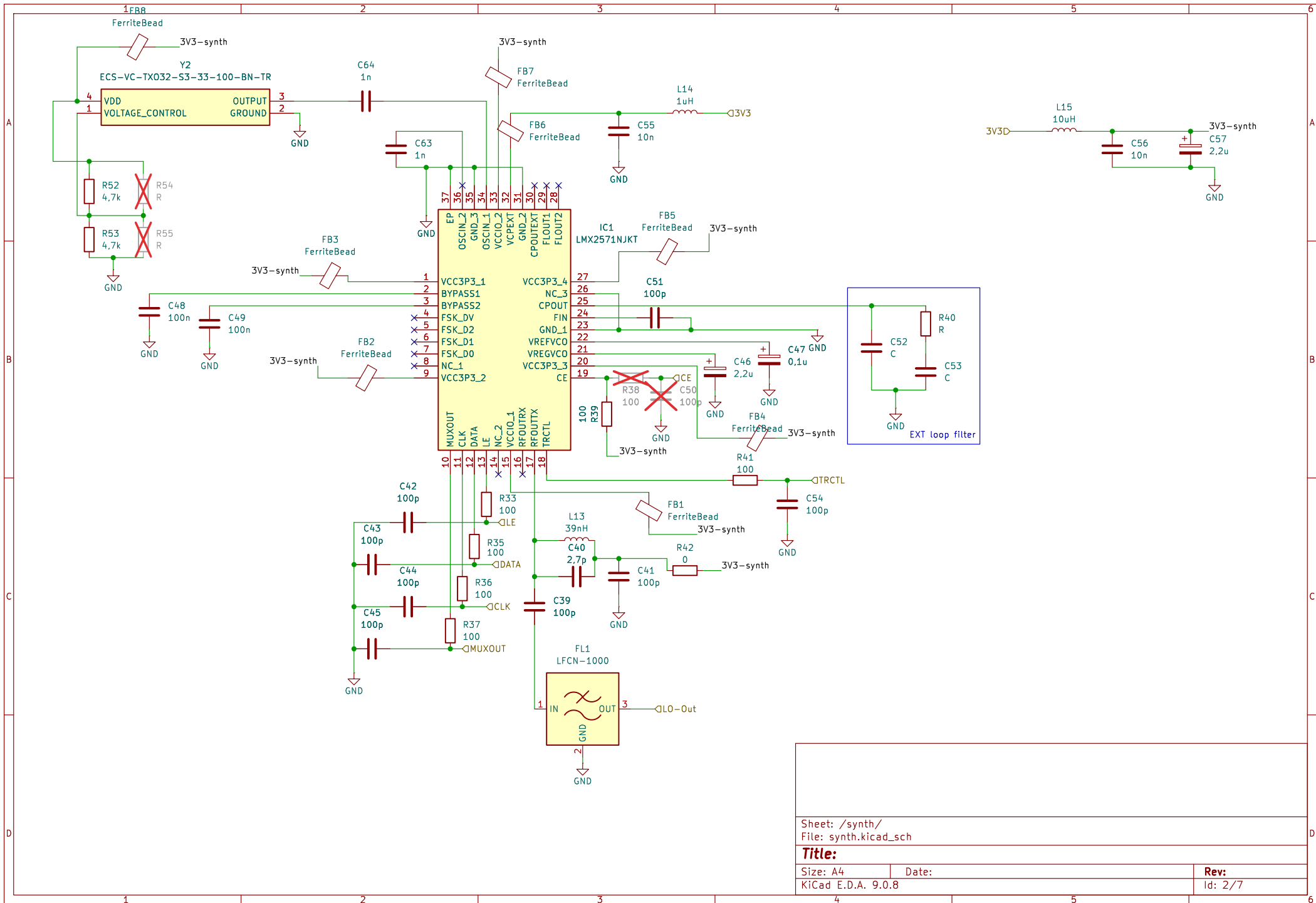

Sheet: /synth/
 File: synth.kicad_sch

Title:

Size: A4
 KiCad E.D.A. 9.0.8

Date:

Rev:

Id: 2/7

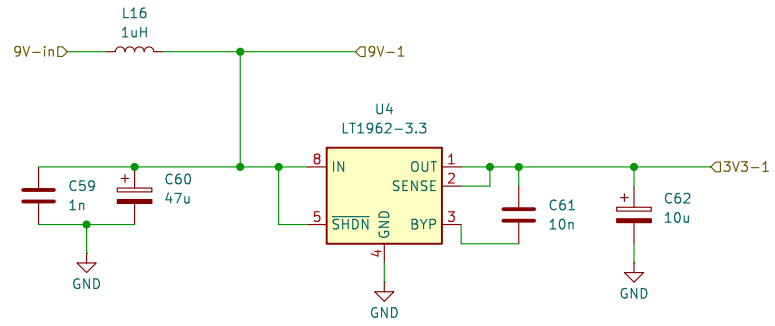

Sheet: /psu/
 File: psu.kicad_sch

Title:

Size: A4
 KiCad E.D.A. 9.0.8

Date:

Rev:
 Id: 3/7

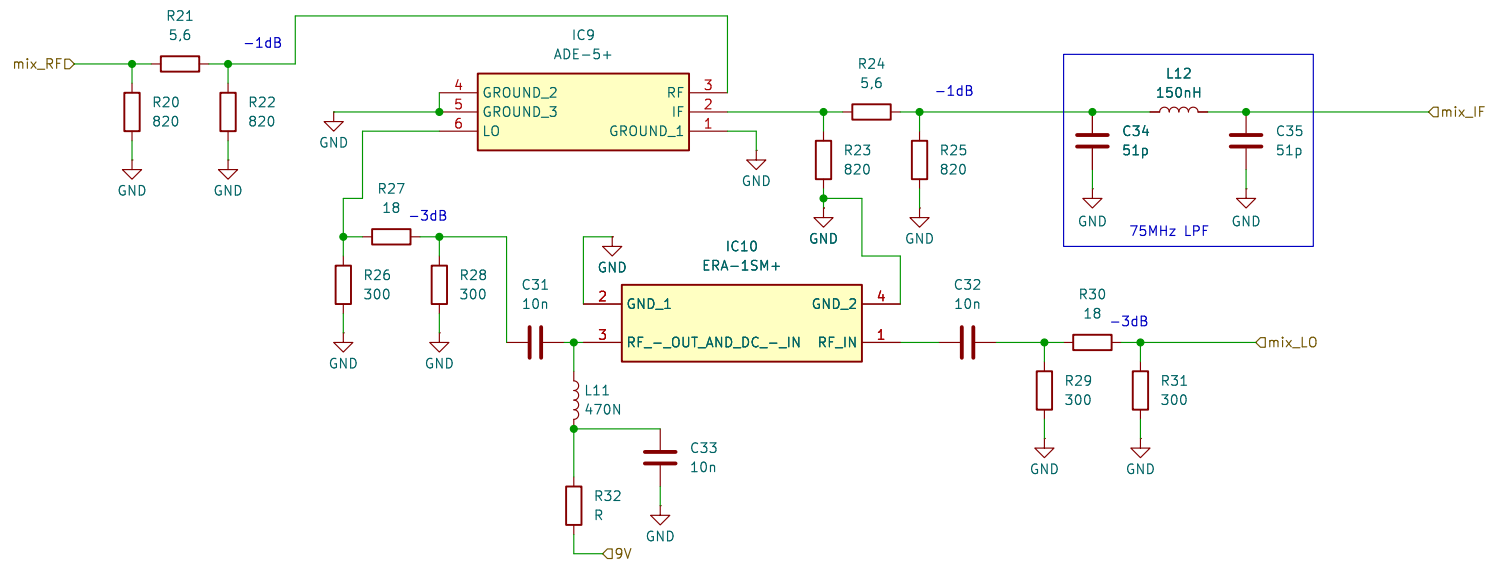

Sheet: /mixer/
 File: mixer.kicad_sch

Title:

Size: A4
 KiCad E.D.A. 9.0.8

Date:

Rev:
 Id: 4/7

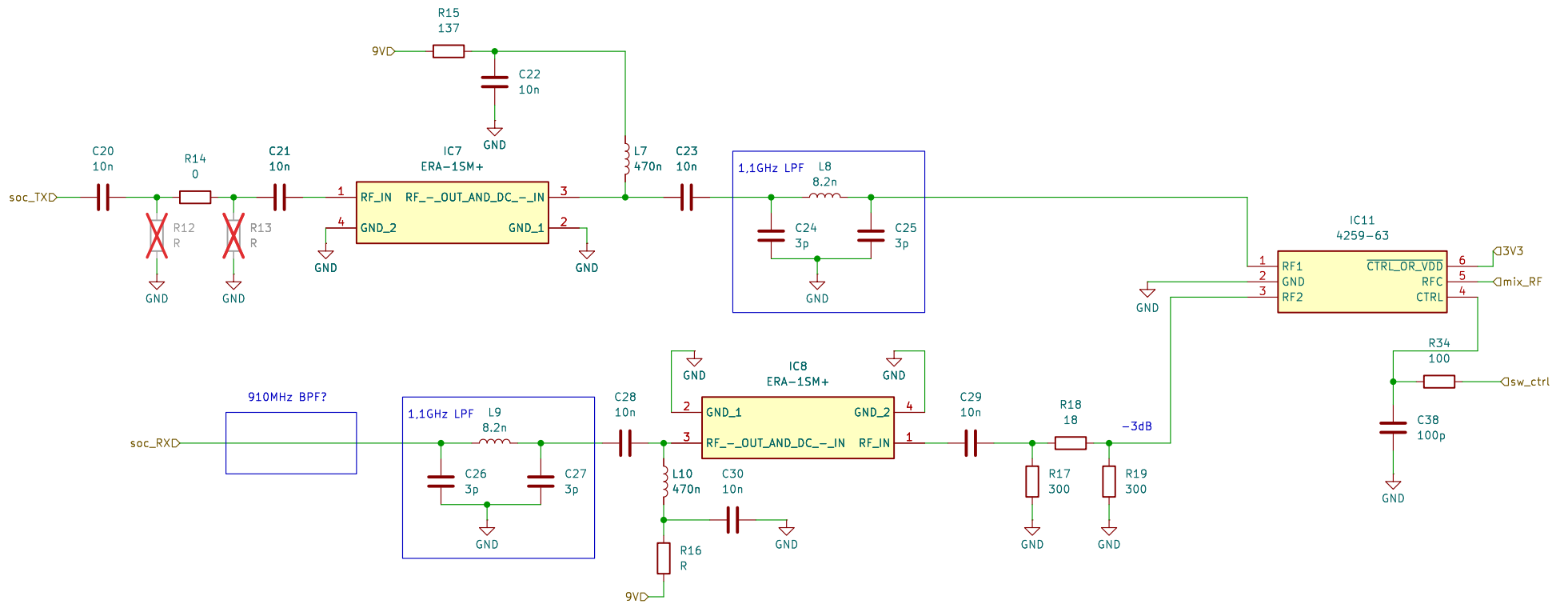

Sheet: /soc_interface/
 File: soc_interface.kicad_sch

Title:

Size: A4 Date:
 KiCad E.D.A. 9.0.8

Rev:
 Id: 5/7

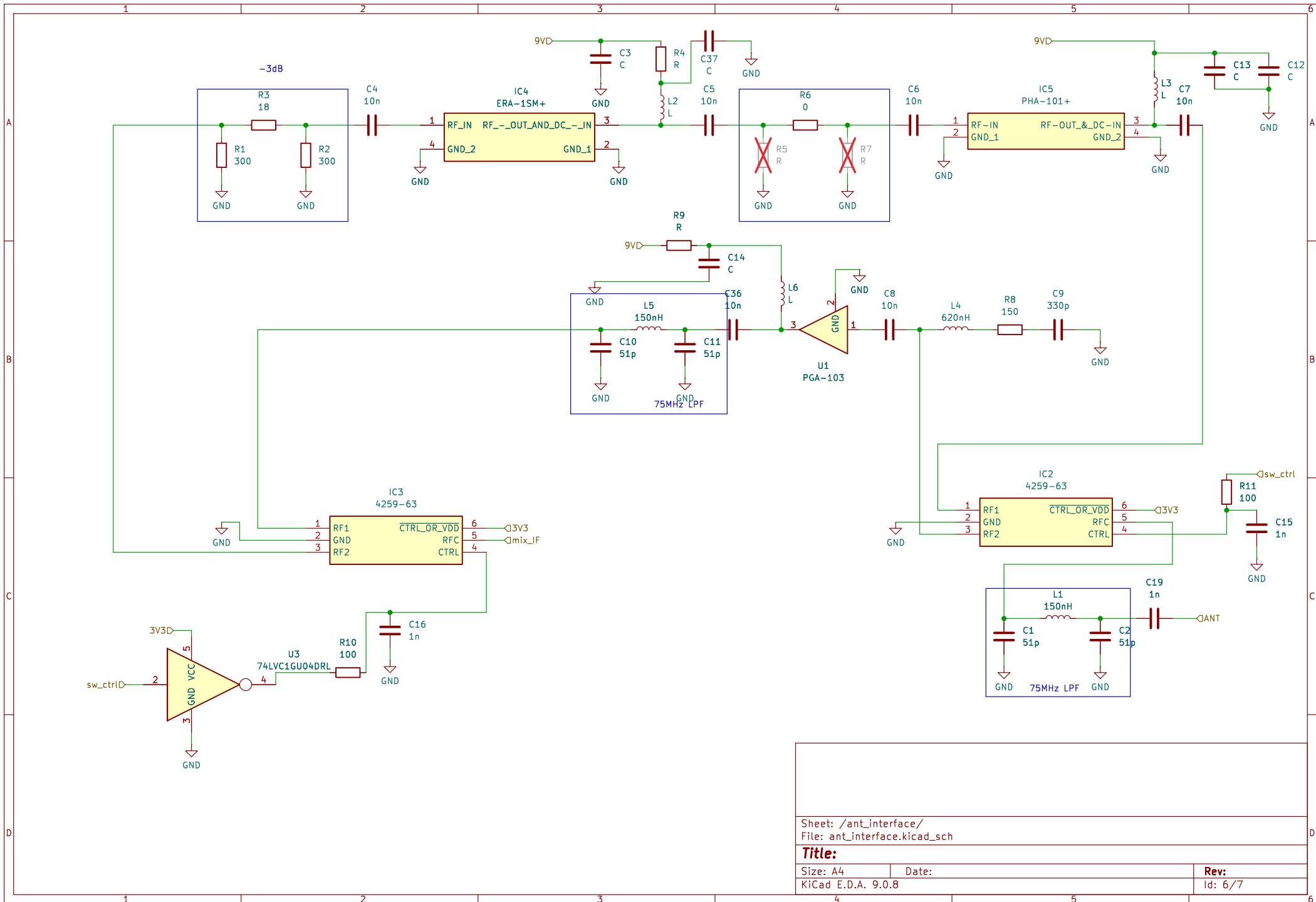

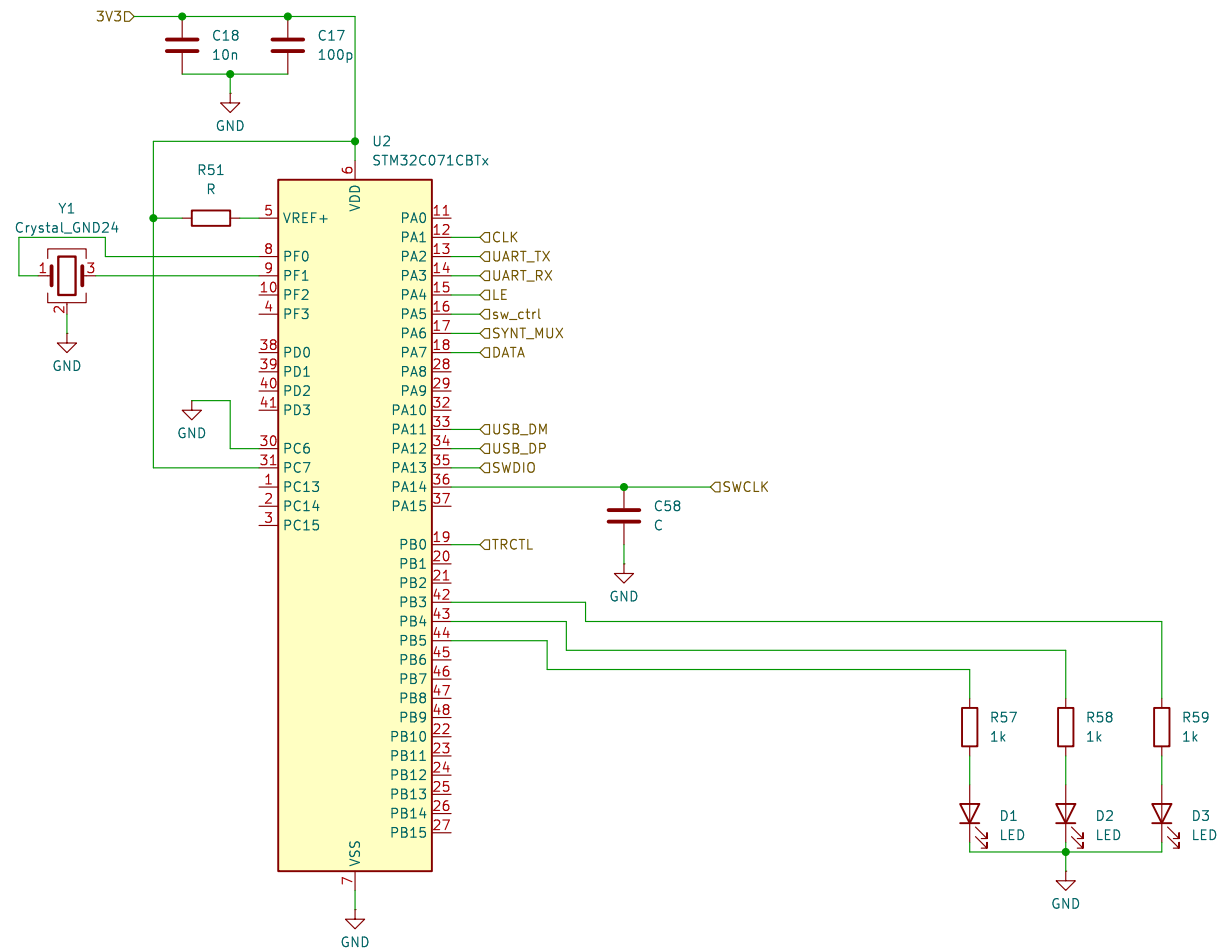

Sheet: /mcu/
File: mcu.kicad_sch

Title:

Size: A4
KiCad E.D.A. 9.0.8

Date:

Rev:
Id: 7/7